

Extra-Length Laminated Dock Bumpers

Material/Thickness

- Made of tough rubberized fabric pads, 4-1/2" or 6" thick cut from selected recycled truck tires.
- Rubber pads laminated between heavy structural steel angles and secured with 3/4" steel tie rods.

Installation

- Structural mounting angles permit welded installations or provide bolting through steel.
- Four options for anchorage devices for extra-length bumpers.

Specifications

- Furnish and install extra-length laminated rubber dock bumpers as manufactured by Durable Corporation, Norwalk, Ohio. Model No(s)_____. Resilient rubber material of bumpers shall be rubberized-fabric truck tires cut to uniform size pads either 4-1/2" x 10", 6" x 10", 4-1/2" x 12", or 6" x 12". Pads punched to receive 3/4" supporting rods.
- All bumpers are closed with two 1/4" structural angles under approximately 1,500 lbs of pressure. The angles are welded to 3/4" rods at one end and closed with threaded rod and nut at the other end. 1/4" flat plates may be substituted for one or both angles.
- The anchor leg of angle extends a minimum of 3" beyond the rubber surface at either end and contains two or three 13/16" anchor bolt holes as required. (Anchor bolts are supplied separately.)
- Black finish.

Uses/Applications

- Primarily used in conjunction with dock-seal.
- Ideal where dock refrigeration or warmth is needed.

Features

- Dock-seal and bumper interact to totally seal the truck to the dock.
- Provides continuous protection for truck, cargo, dock and shelter to stop wind, snow and rain.
- Custom lengths available.

Benefits

- Prevents loss of refrigeration or warmth.
- Maintenance free—weather resistant.
- Absorbs over 80% of truck impact and shock to protect dock and building.

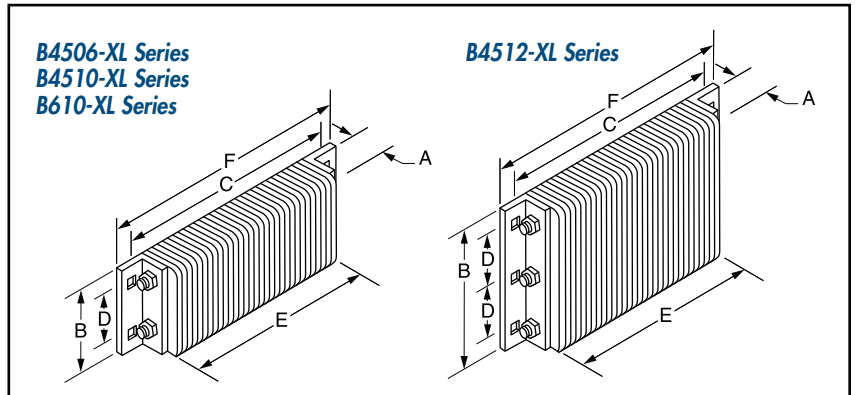
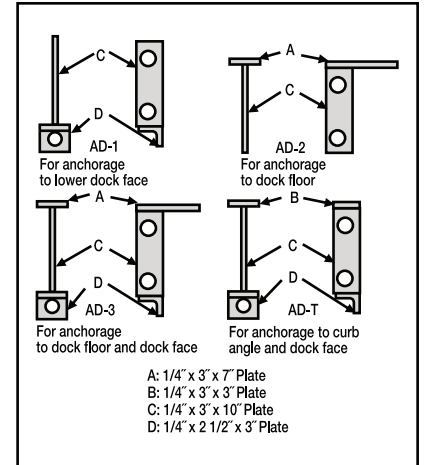

Model	Projection x Height x Bolt Hole Centers (Length) (A x B x C) Size	D Vertical Bolt Hole Centers	E Rubber Length	F Overall Length	Wt. lbs.
B4506-87-A*	4-1/2" x 6" x 7'3"	3"	6'-11"	7'-5"	98
B4506-99-A*	4-1/2" x 6" x 8'3"	3"	7'-11"	8'-5"	121
B4510-51-A*	4-1/2" x 10" x 4'3"	6"	3'-11"	4'-5"	101
B4510-63-A*	4-1/2" x 10" x 5'3"	6"	4'-11"	5'-5"	124
B4510-75-A*	4-1/2" x 10" x 6'3"	6"	5'-11"	6'-5"	147
B4510-87-A*	4-1/2" x 10" x 7'3"	6"	6'-11"	7'-5"	172
B4510-99-A*	4-1/2" x 10" x 8'3"	6"	7'-11"	8'-5"	193
B4510-111-A*	4-1/2" x 10" x 9'3"	6"	8'-11"	9'-5"	218
B4510-123-A*	4-1/2" x 10" x 10'3"	6"	9'-11"	10'-5"	238
B4512-51-A*	4-1/2" x 12" x 4'3"	4"	3'-11"	4'-5"	120
B4512-63-A*	4-1/2" x 12" x 5'3"	4"	4'-11"	5'-5"	148
B4512-75-A*	4-1/2" x 12" x 6'3"	4"	5'-11"	6'-5"	175
B4512-87-A*	4-1/2" x 12" x 7'3"	4"	6'-11"	7'-5"	202
B4512-99-A*	4-1/2" x 12" x 8'3"	4"	7'-11"	8'-5"	230
B4512-111-A*	4-1/2" x 12" x 9'3"	4"	8'-11"	9'-5"	258
B4512-123-A*	4-1/2" x 12" x 10'3"	4"	9'-11"	10'-5"	284

*Refer to illustration AD-1, AD-2, AD-3 or AD-T for type of anchorage device. AD-3 is standard unless otherwise specified.
NOTE: 6" projection also available in standard sizes.