

Dura-Soft Bumpers™

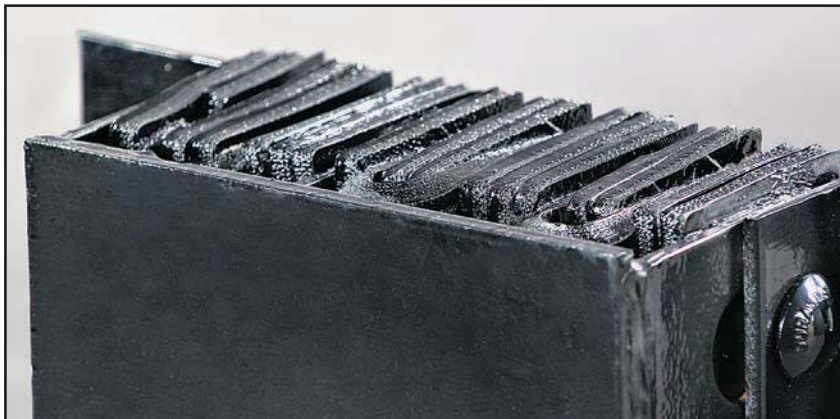

Uses/Applications

- Provides maximum protection with a unique "loop" design of bumper pads—the greatest impact absorption available on the market. Loop-design laminated bumper is a Durable industry innovation.
- Durable's patented design has been thoroughly tested to prove that it provides maximum protection while maintaining the high-quality, heavy-duty dock and truck protection expected of a Durable bumper.
- Steel-Face plate makes the Dura-Soft Bumper™ ideal for use in docking areas where excessive friction from up-and-down trailer movement occurs.
- Can be used in any material-handling system area where heavy-duty protection is required.

Features

- Unparalleled ability to deflect and absorb shock with loop design laminated bumper beneath a floating steel-face.
- Available in a wide variety of models, and can be mounted in various heights, from flush mount to 12" above dock, depending on highest impact area.

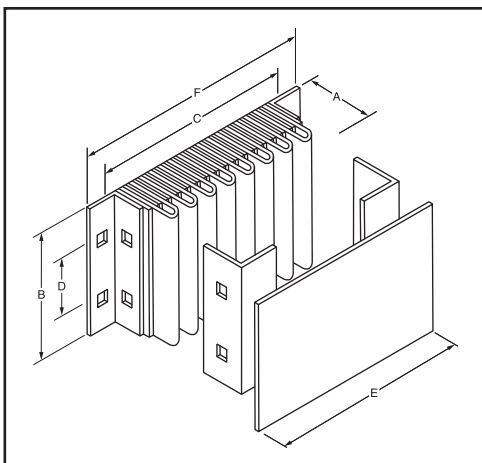

Benefits

- Maximum dock and truck protection available.
- Eliminates wear from up-and-down friction movement of trailer loading and unloading.
- Impervious to weather damage.
- Maintenance free.
- 5 year warranty.
- Cost effective.

Material/Thickness

- Rubber pads 4" thick with loop pad and 3/8" steel-face for overall thickness at 5-1/2".

Installation

- Structural mounting angles permit welded installations or provide bolting through steel.
- No assembly required.

Specifications

- Furnish and install Durable Dura-Soft Bumpers™ as manufactured by Durable Corporation, Norwalk, Ohio. Model No(s) _____.
- Resilient rubber material of bumpers shall be cut to uniform size pads 4" thick with overall projection of 5-1/2". Longer, looped pads inserted between standard spacer pads to allow approximately 1/2" flex of looped pads upon impact. Pads punched to receive 3/4" supporting rods.
- Bumper to have 3/8" steel-face plate equal to the rubber surface dimensions. Plate to be welded to slotted steel support plates which extend back to the 3/4" supporting rods. Brackets to be punched with elongated slots to allow steel-face to "float" on impact.
- Finish to be black only.

Model	Projection x Height x Bolt Hole Centers (Length) (A x B x C) Size	D Vertical Bolt Hole Centers	E Rubber Length	F Overall Length	Wt. lbs.
B5510-14-DS	5-1/2" x 10" x 14"	6"	10"	16"	48
B5510-18-DS	5-1/2" x 10" x 18"	6"	14"	20"	58
B5510-24-DS	5-1/2" x 10" x 24"	6"	20"	26"	73
B5510-36-DS	5-1/2" x 10" x 36"	6"	32"	38"	72
B5512-14-DS	5-1/2" x 12" x 14"	4"	10"	16"	35
B5512-18-DS	5-1/2" x 12" x 18"	4"	14"	20"	44
B5512-24-DS	5-1/2" x 12" x 24"	4"	20"	26"	58
B5512-36-DS	5-1/2" x 12" x 36"	4"	32"	38"	84
B5520-11-DS	5-1/2" x 20" x 11"	6"	7"	13"	73
B5524-11-DS	5-1/2" x 24" x 11"	4"	7"	13"	56
B5536-11-DS	5-1/2" x 36" x 11"	4"	7"	13"	85